

مطالعه آزمایشگاهی اثر کاتالیزوری ترکیبات آهن در تولید نانوساختارهای کربنی از زغال سنگ

مطهره و کیلی فتح آبادی، حسن هاشمی پور رفسنجانی*، فیروزه دانافر

گروه مهندسی شیمی، دانشکده فنی و مهندسی، دانشگاه شهید باهنر کرمان، کرمان، ایران

تاریخ دریافت: ۲۳ اسفند ۱۳۹۶ تاریخ پذیرش: ۲۵ اسفند ۱۳۹۶

Experimental Study on Catalytic Effect of Iron Compounds During Synthesis of Carbon Nanostructures From Coal

M.V. Fathabadi, H.H. Rafsanjani*, F. Danafar

Chemical Engineering Department, Shahid Bahonar University of Kerman,

P.O. Box 76175-133, Kerman, Iran

Received: 14 March 2017

Accepted: 16 March 2018

چکیده

در این مطالعه نانوفایبرها و نانومیله‌های کربنی با استفاده از زغال سنگ (اندازه ذرات کمتر از ۱۰۵ میکرون) به عنوان منبع کربنی و نانوذرات (۵۰ تا ۷۰ نانومتري) $Fe_2(SO_4)_3 \cdot xH_2O$ و فروسن به عنوان کاتالیزور در فاز جامد در دمای ۸۰۰ درجه سانتیگراد سنتز شد. علاوه بر این تاثیر کاتالیزوری $Fe_2(SO_4)_3 \cdot xH_2O$ روی زغال سنگ مورد مطالعه قرار گرفت. نمونه‌های سنتز شده با استفاده از میکروسکوپ الکترونی روبشی و عبوری، طیف‌سنجی پراش انرژی و پراش اشعه ایکس آنالیز شدند. نتایج نشان داد که نانوساختارهای کربنی آمورف مانند نانوفایبرها و نانومیله‌های کربنی تشکیل شده است. قطر نانوفایبرها و نانومیله‌ها در حد ۳۰-۴۰ و ۶۰-۸۰ نانومتر می‌باشد. تاثیر کاتالیزور جامد بر شکل‌گیری نانوساختارهای کربنی مورد بحث قرار گرفته است.

واژه‌های کلیدی

پیش‌تغلیظ؛ نانو فایبر کربنی؛ نانومیله کربنی؛ زغال سنگ؛ کاتالیزور آهن.

Abstract

Carbon nanofibers (CNFs) and carbon nanorods (CNRs) are synthesized using coal particles (<44micron) as carbon source in the presence of Ferrocene and Fe_3O_4 nanoparticles (50-70nm) as catalysts in solid phase at 800°C. Additionally the catalytic effect of $Fe_2(SO_4)_3 \cdot xH_2O$ on the coal particles was studied. The as-synthesized samples have been characterized through scanning electron microscopy (SEM), field emission scanning electron microscopy (FESEM), transition electron microscopy (TEM), energy-dispersive X-ray spectroscopy (EDX) and X-Ray Diffraction (XRD). The results revealed amorphous carbon nanostructures such as: CNFs and CNRs are formed. The diameter of CNFs and CNRs are in the range of 30-40 nm and 60-80nm respectively. The effect of solid catalysts on the formation of carbon nanostructures described here.

Keywords

Carbon Nanofiber; Carbon Nanorod; Coal; Iron Catalyst.

1. INTRODUCTION

The first mention of forming carbon filaments from the thermal decomposition of gaseous hydrocarbon (methane) was reported by Hughes in 1889 [1].

Pang et al. used coal in the arc discharged method for the first time. They presented three ways for preparation of coke electrodes from coal [2].

The arcing methods have been continued by Qiu et al [3-6].

Also Qiu et al. reported synthesis of carbon nanostructures form coal gas by chemical vapor deposition (CVD) method [7].

In these methods, coal should be changed to char, coke or coal gas by two or three preparation processes. Recently Fathabadi et al reported direct synthesis of carbon nanostructures from coal impregnated with Ferrocene by a one step method; catalytic chemical solid synthesis (CCSS) method [8].

In addition to the above methods, Ye et al. reported a facile approach to synthesize tunable graphene quantum dots from various types of coal. These structures were obtained by sonicating the bituminous coal in concentrated sulphuric acid and nitric acid, followed by heat

treatment at 100 or 120°C for 24 h [9].

Iron and iron compounds are widely used catalysts for the growth of carbon nanostructures. He et al. show that both Fe_3C and $\alpha\text{-Fe}$ can act as catalysts for the growth of carbon nanostructures, but the carbide appears to operate at $<600^\circ\text{C}$ and the growth rate of CNFs from carbide appears largely lower than that of CNFs from Fe at higher temperatures (650 and 725°C) [10].

Also they synthesized well-crystallized hexagonal MWCNTs at a low temperature (650°C) using Fe particles as catalysts. They found that the hexagonal prism of the Fe nanoparticles is the origin of the hexagonal shape of the MWCNT because the graphene layers around the particle are parallel to its side surfaces. The morphology of the corresponding Fe catalyst was found to be the driving force for the hexagonal characteristics of the MWCNT [11].

Maksimova et al. prepared carbon nanostructures by heating a uniform distribution of iron catalyst particles in the polymer (polyethylene and polyvinyl alcohol) bulk. Heating the blend to 600°C under flowing nitrogen led to the formation of amorphous carbon incorporating uniformly distributed catalyst particles. Subsequent heating of the samples to 750°C in a nitrogen flow led to the catalytic graphitization of the amorphous carbon matrix with the formation of different carbon nanostructures [12].

He et al. found the angle of CNFs layers is determined by the shape of metal nanoparticle used to catalyze the growth [13].

In this study, synthesis of carbon nanostructures with different morphology is investigated from coal. Iranian coal is selected as the carbon precursor which is mixed with several Fe components as catalysts. Catalytic effect of the components is investigated on the structure of formed carbon.

The carbon nanostructures were characterized by techniques including SEM, FESEM, TEM, EDX and XRD. The results show CNFs (mean diameters: 30-40 nm) and CNRs (mean diameters: 60-90nm) are formed from coal by $(\text{C}_5\text{H}_5)_2\text{Fe}$, Ferrocene and Fe_3O_4 nanoparticles as catalyst respectively. Carbon nanostructures are not formed in presence of $\text{Fe}_2(\text{SO}_4)_3 \cdot x\text{H}_2\text{O}$ powder.

2. EXPERIMENTAL

All chemicals used in the study were supplied as analytical grade. The coal sample is prepared from the Pabdana coal mine, Iran. The component and elemental analyses of the as-received coal sample are carried out by thermo gravimetric analyzer (TG–DSC), (STA409PG under N_2 flow) and elemental analyzer (GC Column: SS 6×5 mm- 2m- HayeSep Q 60/80) respectively. The results of these analyses are summarized in Table 1.

The ash was analyzed by X-ray fluorescence spectrometer; Philips PW 1410 type.

Ferrocene and hydrated Iron (III) Sulfate supplied by Merck (Darmstadt, Germany) and Fe_3O_4 nanoparticles (50-70nm) supplied by Sigma Aldrich Company were used as catalysts in the synthesis method.

The coal samples were first crushed and sieved to obtain particles with diameter of less than 44 micron; then mixed with three iron catalysts; Ferrocene (S_1 sample), Fe_3O_4 nanoparticles (50-70nm) (S_2 sample) and $\text{Fe}_2(\text{SO}_4)_3 \cdot x\text{H}_2\text{O}$ (S_3 sample) by an experimental mill (IKA A11 model) for 2 hours. The ratio of catalyst to coal was 1:14. The solid powders including coal and catalyst was placed in a ceramic boat within a reactor. The reactor is shown schematically in Fig. 1.

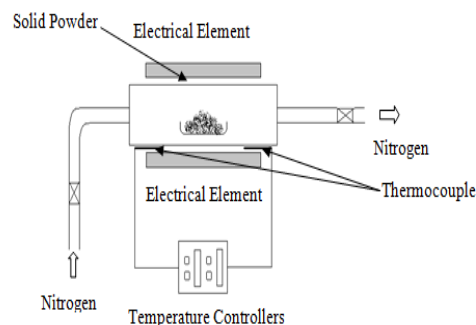

Fig. 1. Schematic set-up for synthesis of nanostructures from coal of CNFs; a, CNRs; b.

Table 1. Analysis of the raw coal and ash.

| Proximate analysis (W. %) and Ultimate analysis (%) | | | | | | | | | |
|-----------------------------------------------------|-------------------------|-------------------------|--------------|------|----------------------|-----------------------|----------------|------------------------|-------|
| Moisture | Volatile Matter | Ash | Fixed Carbon | C | H | N | S | | |
| 1.06 | 20.07 | 8.75 | 70.12 | 72 | 3.6 | 0.57 | 6.42 | | |
| XRF analysis of the ash (mol %) | | | | | | | | | |
| SiO_2 | Al_2O_3 | Fe_2O_3 | CaO | MgO | K_2O | Na_2O | TiO_2 | P_2O_5 | MnO |
| 10.6 | 6.1 | 1.42 | 1.05 | 0.50 | 0.98 | 0.22 | 0.15 | 0.07 | 0.015 |

The dimension of reactor chamber is $36 \times 26 \times 32$ cm³. It equipped with a temperature controlling system. The atmosphere in the chamber was adjusted by a continuous stream of nitrogen. The solid mixture was heated to 800°C at a heating rate of 80°C/min for 1 hour under nitrogen atmosphere. The black powder product containing carbon nanostructure was characterized using SEM (EM3200), FESEM (MIRA3TESCAN-XMU), TEM (PHILIPS CM20), EDX instrument (Mira 3-XMU) and XRD instrument (PHILIPS, X'pert -MPD system, $\lambda = 1.54 \text{ \AA}$).

3. RESULT AND DISCUSSION

The SEM images for $S_{1,2}$ are shown in Fig. 2a,b respectively.

Fig. 2a clearly shows that woven CNFs can be prepared in S_1 sample. Their diameters are almost the same and the average diameter is about 25–40nm.

CNRs are observed in SEM image of S_2 sample which are shown in Fig. 2b. The average diameter of them is about 60–90nm and all emanating from a central core.

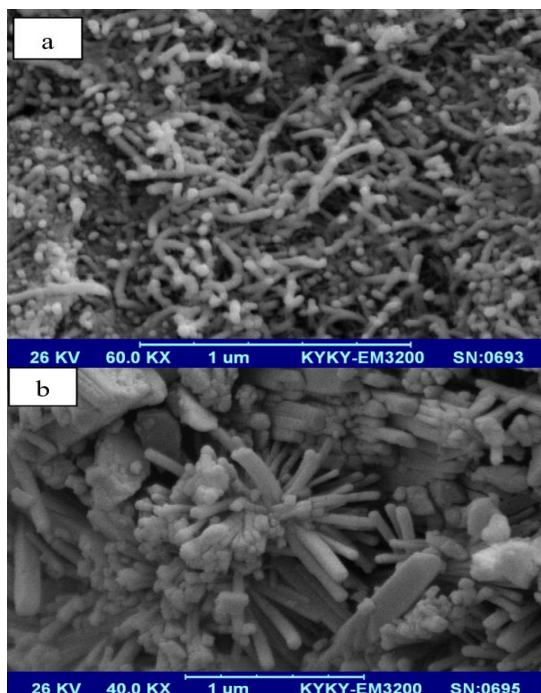

Fig. 2. SEM images of CNFs; a, CNRs; b.

The structural details of CNFs are shown by TEM image; Fig. 3.

Fig. 3 shows that the surface of the CNFs is rather rough, uniform and consists of nanorods with a diameter about 26nm [8].

The structural details of CNRs are shown by FEEM image; Fig. 4.

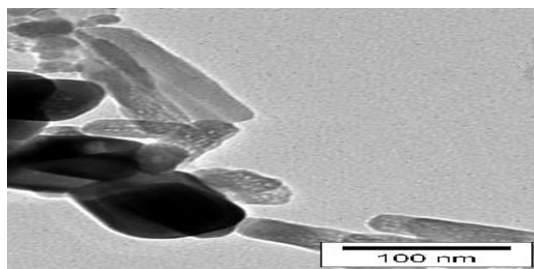

Fig. 3. TEM images of CNFs.

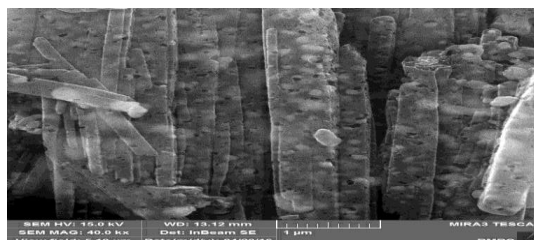

Fig. 4. FESEM images of CNRs.

Fig. 4 shows that the formation of sprouts and thin wall amorphous CNRs with some pores. The diameter of some CNRs is about 50nm.

The SEM images of S_3 are shown in Fig. 5. Catalytic effect of hydrated Iron (III) Sulfate powder is not observed. The elemental analysis and EDX pattern of $S_{1,2}$ sample are reported according to Table 2 and Fig. 6a,b. Mole ratio Fe/C (fixed content not volatile matter) in the solid powder is changed from 0.0066 to 0.0264 for S_1 . It means that Fe atoms diffuse to fixed carbon matrix after decomposition of Ferrocene. Also mole ratio Fe/C (fixed carbon content not volatile matter) in the solid powder is changed from 0.0222 to 0.0247 for S_2 . It means that the content of iron and fixed carbon of solid phase has not changed much and the formation of CNRs take place by rearrangement of carbon structures in solid phase.

Table 2. Elemental analysis of $S_{1,2}$ sample by EDX.

| Element | C | O | Fe | S | Mn |
|------------|-------|-------|------|------|------|
| S_1 (W%) | 76.39 | 12.62 | 9.20 | 0.27 | 1.51 |
| S_2 (W%) | 72.81 | 18.80 | 8.39 | | |

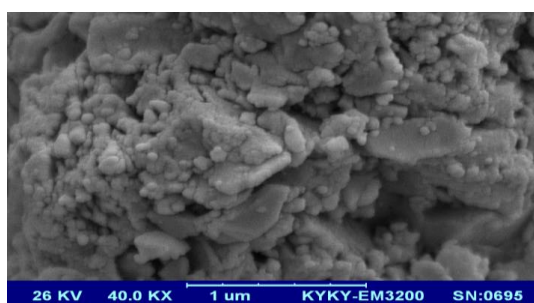

Fig. 5. SEM images of structures prepared from S_3 sample.

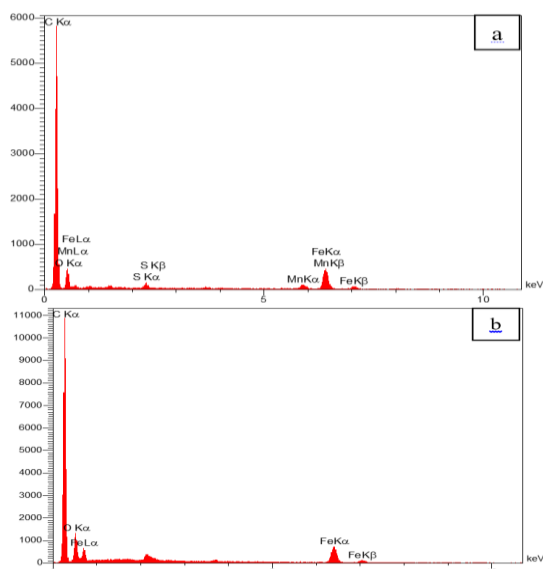

Fig. 6. EDX pattern of S1 sample (a), S2 sample (b).

The XRD pattern for S₁ and S₂ samples are shown in Fig. 7a,b respectively. Amorphous carbon (JCPDS file no. 75-0444) is detected due to the broad diffraction first peak shown in XRD patterns. S₁ sample also contains the less graphite phase of carbon (JCPDS file no. 80-0004) and Fe atoms act as catalyst in form α-Fe; (JCPDS file no. 85-1410) that obtained from decomposition of Ferrocene.

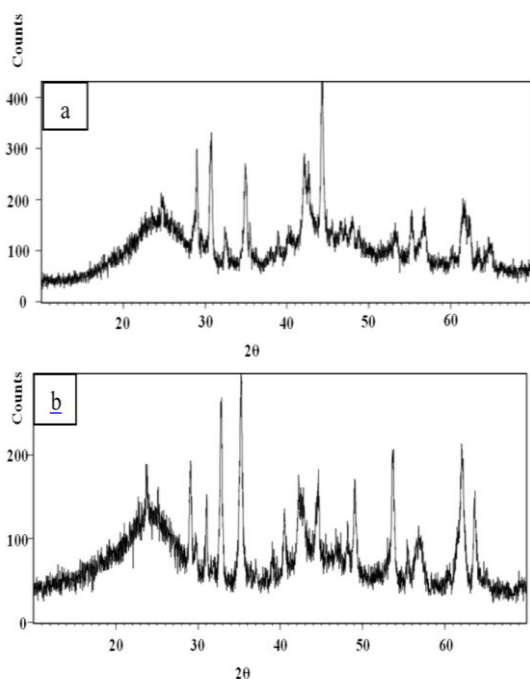

Fig. 7. XRD patterns.

S₂ sample contains Fe atoms in three forms: (JCPDS file no. 01-1111 Fe₃O₄, 79-0007 Fe₂O₃ and 87-0722 Fe).

The all samples did not wash and therefore the backgrounds of the SEM images of them are the unreacted coal.

It is clear that the major mineral chemical components in the coal ash are SiO₂, Al₂O₃, Fe₂O₃ and CaO, as shown in Table 2. It is known that Fe species could be the catalyst for the growth of carbon nanostructures. But Fe components in the coal ash have not sufficient effect in the CCSS method for formation of carbon nanostructures [8] and the using of catalysts is necessary.

The concentration of pyrolytic carbon respect to Fe particles that is produced from decomposition of ferrocene was found to plays important role in the formation of different carbon nanostructures [14]. Ring structures and pyrolytic carbon found in coal. The ratio of iron compounds and coal plays important role in the formation of CNFs or CNRs.

To figure out the formation mechanism involved in the process, more detailed work is required, and the work is still in progress.

REFERENCES

- [1] T.V. Hughes and C.R. Chambers, Manufacturing of carbon filaments, US patent, (1889) 405-480.
- [2] P.F. Greenwood, M.G. Strachan, H.J. El-Nakat, G.D. Willett, M.A. Wilson and M. Atta, Laser ablation Fourier transform mass spectrometric investigation of coals and model materials, *Fuel* 69 (1990) 257-260.
- [3] J. Qiu, Y. An, Z. Zhao, Y. Li and Y. Zhou, Catalytic synthesis of single-walled carbon nanotubes from coal gas by chemical vapor deposition method, *Fuel Proc. Technol.* 85 (2003) 913-920.
- [4] J. Qiu, Y. Li, Y. Wang, C. Liang, T. Wang and D. Wang, A novel form of carbon micro-balls from coal, *Carbon* 41 (2003), 767-772.
- [5] J. Qiu, Y. Li and Y. Wang, Novel fluffy carbon balls obtained from coal which consist of short curly carbon fibres, *Carbon* 42 (2004) 2329-2366.
- [6] J. Qiu, Y. Li, Y. Wang, W. Li, Production of carbon nanotubes from coal, *Fuel Proc. Technol.* 85 (2004) 1663-1670.
- [7] J. Qiu, F. Zhang, Y. Zhou, H.M. Han, D.S. Hu, S.C. Tsang and P.J.F. Hariss, Carbon nanomaterials from eleven caking coals, *Fuel* 81 (2002) 1509-1514.
- [8] M.V. Fathabadi, H.H. Rafsanjani and F. Danafar, Synthesis of carbon nanostructures from coal by Chemical Solid Synthesis (CSS) method, *Micro Nano Let* 11 (2016) 450-453.
- [9] R. Ye, C. Xiang, J. Lin, Z. Peng, K. Huang, Z. Yan, N.P. Cook, E.L.G. Samuel, C.C. Hwang, G.

Ruan, G. Ceriotti, A.R.O. Raji, A. Mart and A.J.M. Tour, Coal as an abundant source of graphene quantum dots, *Nature Commun.* 4 (2013) 2943-2950.

[10] Z. He, J.L. Maurice, A. Gohier, C.S. Lee, D. Pribat and C.S. Cojocaru, Iron Catalysts for the Growth of Carbon Nanofibers: Fe, Fe₃C or Both?, *Chem. Mater.* 23 (2011) 5379–5387.

[11] Z. He, X. Ke, S. Bals and G.V. Tendeloo, Direct evidence for the existence of multi-walled carbon nanotubes with hexagonal cross-sections, *Carbon* 50 (2012) 2524–2529.

[12] N.I. Maksimova, O.P. Krivoruchko, G. Mestl, V.I. Zaikovskii, A.L. Chuvilin, A.N. Salanov and E.B. Burgina, Catalytic synthesis of carbon nanostructures from polymer Precursors, *J. Mol. Catal. A: Chem.* 158 (2000) 301–307.

[13] Z.B. He, J.L. Maurice, C.S. Lee, A. Gohier, D. Pribat, P. Legagneux and C.S. Cojocaru, Etchant-induced shaping of nanoparticle catalysts during chemical vapour growth of carbon nanofibres, *Carbon* 49 (2011) 435–444.

[14] X. Liu, Y. Yang, W. Ji, H. Liu, C. Zhang and B. Xu, Controllable growth of nanostructured carbon from coal tar pitch by chemical vapor deposition, *Mater. Chem. Phys.* 104 (2007) 320–326.